

Can We Approximate Zeros
of Functions with Non-zero
Topological Degree?

T. Boult

K. Sikorski*

July 1984

Department of Computer Science
Columbia University
New York

*This research was supported in part by the National Science
Foundation under Grant MCS 7823676.

Abstract.

The bisection method provides an affirmative answer for scalar functions. We show that the answer is negative for bivariate functions. This means, in particular, that an arbitrary continuation method cannot approximate a zero of every smooth bivariate function with non-zero topological degree.

1. Introduction.

Assume that f is a scalar continuous function defined on an interval $[a,b]$ in \mathbb{R} such that $f(a) \cdot f(b) < 0$. This inequality is equivalent to the assumption that f has non-zero topological degree since $\deg(f, [a,b], 0) = (\text{sgn}(f(b)) - \text{sgn}(f(a)))/2$. It is known that for arbitrary positive ϵ we can find an ϵ -approximation x^* , $|x^* - \alpha(f)| \leq \epsilon$, to a zero $\alpha(f)$ of such a function f , and that the bisection method is optimal, see [5]. If the degree of f is zero then, in general, there exists no algorithm using linear information on f to find x^* , see [6]. Thus the degree decides whether we can or cannot solve the problem for the scalar case.

The situation drastically changes when we add just one more dimension. We show that in general it is impossible to find an ϵ -approximation to a zero of a bivariate smooth function with non-zero topological degree.

More precisely, we assume that f is defined on a unit triangle T in \mathbb{R}^2 and that T is completely labeled under f . The information on f consists of n values of arbitrary linear functionals which are computed adaptively and an algorithm constructing x^* is an arbitrary mapping

based on these evaluations. We show that for arbitrary n and $\epsilon < \text{diam}(T)/2$ there exists no algorithm to find x^* for some f .

Our result indicates, in particular, that arbitrary continuation and/or simplicial continuation method cannot approximate zeros of every function f to within $\epsilon < \text{diam}(T)/2$, with any, a priori fixed number of function and/or derivative evaluations. We conclude that additional restrictions on f must be imposed to obtain positive results.

We remark that the unit triangle was chosen as the domain of f only for technical reasons and that the result holds for arbitrary compact domain D with $\epsilon < \text{diam}(D)/2$.

We briefly summarize the contents of the paper. In Section 2 we give the basic definitions and formulate the problem. In Section 3 we prove two auxiliary lemmas and in Section 4 we prove the main theorem.

2. Formulation of the problem.

Let $T = \{x \in \mathbb{R}^2: x_i \geq 0, i=1,2, x_1 + x_2 \leq 1\}$ be the unit triangle in \mathbb{R}^2 and $G = C^\infty(\mathbb{R})$ be the class of infinitely differentiable functions on T . Let

$$(2.1) \quad F = \{f \in G: \deg(f, T, \theta) \neq 0, \theta = (0,0), \text{ there exists exactly one } z \in T: f(z) = \theta \text{ and } \theta \in \text{Conv}_f(T)\},$$

where $\deg(f, T, \theta)$ is the topological degree of f relative to T at θ and $\text{Conv}_f(T)$ is the triangle with vertices $f(\theta)$, $f(1,0)$, $f(0,1)$.

We say that T is completely labeled under f (or f -Sperner triangle), see [1,2.3.7], iff $\theta \in \text{Conv}_f(T)$.

We include the assumption $\theta \in \text{Conv}_f(T)$, since it makes our result stronger and it is a typical assumption in the theory of simplicial continuation methods.

Define the solution operator $S: F \rightarrow T$ by

$$(2.2) \quad S(f) = f^{-1}(\theta).$$

Our problem is to find an approximation to $S(f)$. To solve this problem we use adaptive information operators which are defined as follows (see [8]). Let $f \in G$ and

$$(2.3) \quad N_n(f) = [L_1(f), L_2(f, Y_1), \dots, L_n(f; Y_1, \dots, Y_{n-1})]$$

where

$$Y_i = L_i(f; Y_1, \dots, Y_{i-1})$$

and

$$(2.4) \quad L_{i,f}(\cdot) \stackrel{\text{def}}{=} L_i(\cdot; Y_1, \dots, Y_{i-1}): G \rightarrow \mathbb{R}$$

is a linear functional, $i = 1, 2, \dots, n$. Knowing $N_n(f)$ we approximate $S(f)$ by an algorithm φ which is an arbitrary transformation

$$\varphi: N_n(F) \rightarrow T.$$

The error of the algorithm φ is defined by

$$(2.5) \quad e(\varphi) = \sup_{f \in F} \|S(f) - \varphi(N_n(f))\|_2.$$

Let $\Phi(N_n)$ be the class of all algorithms using information operator N_n . It is known, [8], that

$$(2.6) \quad \inf_{\varphi \in \Phi(N_n)} e(\varphi) = r(N_n)$$

where $r(N_n)$, called the radius of information is given by

$$(2.7) \quad r(N_n) = \sup_{f \in F} \text{rad}(U(f))$$

where $\text{rad}(U(f))$ is the radius of the smallest ball containing the set $U(f)$ of zeros of functions from F which share the same information with f ,

$$(2.8) \quad U(f) = \{z \in T: z = S(\tilde{f}), \tilde{f} \in F; N_n(\tilde{f}) = N_n(f)\}.$$

We prove that for an arbitrarily large number of evaluations n and any information of the form (2.3) there exist two functions f and g in F having the same information. $N_n(f) = N_n(g)$, such that $\|S(f) - S(g)\|_2$ is arbitrarily close to $\text{diam}(T)$. This combined with (2.8) and (2.7) yields that the radius of N_n is at least $\text{diam}(T)/2$. By choosing a trivial algorithm $\varphi(N_n(f)) = (\frac{1}{2}, \frac{1}{2})$ we get $r(N_n) = \text{diam}(T)/2$. Thus (2.6) yields that there exist no algorithm for approximating zeros of f in F with error less than $\text{diam}(T)/2$. We formulate this in

Theorem 2.1: For every n and every information N_n the radius $r(N_n)$ is equal to the half diameter of T , i.e.,

$$\forall n, \forall N_n \in \eta_n \quad r(N_n) = \text{diam}(T)/2 = \frac{\sqrt{2}}{2},$$

where η_n is the class of all information of the form (2.3). ■

3. Auxiliary lemmas.

We split the proof of Theorem 2.1 into two lemmas. The first lemma will be proved for an arbitrary number of dimensions. Let \mathbb{M} be a compact region in \mathbb{E}^n , and let $G = G^\infty(\mathbb{M})$ be the class of functions $f: \mathbb{M} \rightarrow \mathbb{E}^n$ which are infinitely differentiable. Let $C(\cup_{i=1}^k B_i)$ denote the set

$$\{f \in G: \text{supp}(f) \subseteq \cup_{i=1}^k B_i\},$$

where B_i are open balls in \mathbb{E}^n . Finally let $L_i: G \rightarrow \mathbb{E}$, $i = 1 \dots k$ be linearly independent linear functionals.

Lemma 3.1: For arbitrarily small positive ϵ , and every family of balls $B_i \cap \mathbb{M} \neq \emptyset$, $i = 1, \dots, (k-1)$ such that L_1, \dots, L_{k-1} are linearly independent on $C(\cup_{i=1}^{k-1} B_i)$, there exists an open ball $B_k \cap \mathbb{M} \neq \emptyset$ with $\text{diam}(B_k) = \epsilon$, such that L_1, \dots, L_k are linearly independent on $C(\cup_{i=1}^k B_i)$. ■

Proof: Suppose the lemma does not hold. Then for every B_k , $B_k \cap \mathbb{M} \neq \emptyset$, with $\text{diam}(B_k) = \epsilon$, the linear functionals L_1, \dots, L_k are linearly dependent on $C(\cup_{i=1}^k B_i)$. Since by assumption, L_1, \dots, L_{k-1} are linearly independent on $C(\cup_{i=1}^{k-1} B_i)$ we must have

$$(3.1) \quad L_k = \sum_{i=1}^{k-1} \alpha_i(B_k) L_i \quad \text{on} \quad C\left(\bigcup_{i=1}^k B_i\right).$$

First let us assume $\alpha_i(B_k) = \alpha_i$ for all B_k (i.e. let the constants of the summation be independent of the choice of B_k). Then let B_1^*, \dots, B_q^* , $q < \infty$, be an open ϵ -covering of \mathbb{M} (i.e. $B_j^* \subset \mathbb{R}^n$ is a ball with $\text{diam}(B_j^*) = \epsilon$ and $\mathbb{M} \subset \bigcup_{j=1}^q B_j^*$). This covering exists since \mathbb{M} is compact. Then by the partition of unity theorem [see 9 p. 60], any $f \in C^\infty(\mathbb{M})$ can be decomposed such that $f(x) = \sum_{j=1}^q f_j(x)$, and $\text{supp}(f_j) \subset B_j^*$. Therefore for all $f \in C^\infty(\mathbb{M})$, we have, by linearity of L_k and by (3.1)

$$L_k(f) = \sum_{j=1}^q L_k(f_j) = \sum_{i=1}^{k-1} \sum_{j=1}^q \alpha_i L_i(f_j) = \sum_{i=1}^{k-1} \alpha_i L_i(f).$$

But this contradicts the linear independence of L_1, \dots, L_k on G . Therefore $\alpha_i(B_k) \neq \alpha_i$, so there exists at least 2 balls B_{k1}, B_{k2} such that

$$L_k = \sum_{i=1}^{k-1} \beta_i L_i \quad \text{on} \quad C\left(\left(\bigcup_{i=1}^{k-1} B_i\right) \cup B_{k1}\right)$$

and

$$L_k = \sum_{i=1}^{k-1} \gamma_i L_i \quad \text{on} \quad C\left(\left(\bigcup_{i=1}^{k-1} B_i\right) \cup B_{k2}\right)$$

where $\beta_i = \alpha_i(B_{k1})$, $\gamma_i = \alpha_i(B_{k2})$, and $\beta_{j'} \neq \gamma_{j'}$, for some $j' \in \{1, \dots, (k-1)\}$. This implies

$$0 = L_k - L_k = \sum_{i=1}^{k-1} (\beta_i - \gamma_i) L_i \quad \text{on} \quad C\left(\bigcup_{i=1}^{k-1} B_i\right).$$

However, since $\beta_{j_i} - \gamma_{j_i} \neq 0$ this contradicts the linear independence of L_1, \dots, L_{k-1} on $C\left(\bigcup_{i=1}^{k-1} B_i\right)$.

Thus the lemma holds. ■

Lemma 3.2: For every $N_n \in \mathcal{N}_n$, every ϵ , $0 < \epsilon \leq \frac{1}{2} \text{diam}(T)$, and for every γ_n , $0 < \gamma_n < (a/2^{2n+3})$, $a = \sqrt{\epsilon/8}$, there exists:

- a function $F_n = (f_n^1, f_n^2) \in C^\infty(T)$,
- strips S_n^x, S_n^y (defined below),
- and balls B_i with $\text{diam}(B_i) \leq \gamma_i$, $i = 1, \dots, k_n$,

where k_n is the maximal number of linearly independent functionals on $C^\infty(T)$ among $L_{1, F_n}, \dots, L_{k_n, F_n}$. (Let us denote these functionals as $L_1^*, \dots, L_{k_n}^*$.) Such that:

$$(3.2i) \quad S_n^x = \begin{cases} (x, y) \in T: 1 - 2a \leq S_{n,1}^x \leq x \leq S_{n,2}^x \leq 1-a; \\ S_{n,2}^x - S_{n,1}^x \geq \frac{a}{2^{2n+1}} \end{cases}$$

$$(3.2ii) \quad S_n^y = \begin{cases} (x, y) \in T: 1 - 2a \leq S_{n-1}^y \leq y \leq S_{n-2}^y \leq 1-a; \\ S_{n,2}^y - S_{n-1}^y \geq \frac{a}{2^{2n+1}} \end{cases}$$

(i.e. strips S_n^x and S_n^y are at least $\frac{a}{2^{2n+1}}$ units wide).

(3.2iii) $\text{dist}(S_n^x, S_n^y) \geq \text{diam}(T) - \epsilon$, where given

sets $W, Z \subset \mathbb{R}^2$ $\text{dist}(W, Z) \stackrel{\text{df}}{=} \inf_{w \in W, z \in Z} \|w - z\|_2$ and $\text{dist}(W, Z) = +\infty$ if

W or $Z = \emptyset$.

$$\text{dist}(B_i, S_n^x) \geq \frac{y_n}{2} \quad i = 1, \dots, k_n$$

(3.2iv)

$$\text{dist}(B_i, S_n^y) \geq \frac{y_n}{2} \quad i = 1, \dots, k_n$$

(3.2v) Triangle T is F_n -Sperner Triangle

and

$$(3.2vi) \quad F_n(x, y) = (f_n^1(x, y), f_n^2(x, y))$$

where

$$f_n(x, y) \text{ is: } \begin{cases} > 0, & (x, y) \in T: 0 \leq x \leq s_{n,1}^x \text{ and } 0 \leq y \leq s_{n,1}^y; \\ = 0, & (x, y) \in T: (x, y) \in (S_n^x \cup S_n^y); \\ < 0, & (x, y) \in T: x > s_{n-2}^x, \text{ or } y > s_{n,2}^y \end{cases}$$

for $i = 1, 2$. ■

First we define a function needed in the proof of Lemma

3.2. Let α, β , ($\alpha < \beta$), be fixed real numbers. Define the

function

$$PL(z, \alpha, \beta) = \begin{cases} 1, & z \leq \alpha; \\ \frac{\int_z^\beta e^{-(t-\alpha)^{-2}} (t-\beta)^{-2} dt}{\int_\alpha^\beta e^{-(t-\alpha)^{-2}} (t-\beta)^{-2} dt}, & \alpha \leq z \leq \beta; \\ 0, & z \geq \beta. \end{cases}$$

Proof of Lemma 3.2: The proof is by induction on n .

Suppose first that $n = 0$, i.e. we do not have any information. We construct a function F_0 which satisfies (3.2i)-(3.2vi). Let

$$S_0^x = \{(x,y) \in T: S_{0,1}^x = 1-2a \leq x \leq 1-a = S_{0,2}^x\},$$

$$S_0^y = \{(x,y) \in T: S_{0,1}^y = 1-2a \leq y \leq 1-a = S_{0,2}^y\},$$

and define for all $(x,y) \in T$: (see Fig. 3.1)

$$F_0(x,y) = \begin{cases} (0,0), & (x,y) \in S_0^x \cup S_0^y; \\ (1,1), & x \leq 1-3a, y \leq 1-3a; \\ (PL(x, 1-3a, 1-2a), PL(x, 1-3a, 1-2a)), & 1-3a \leq x \leq 1-2a; \\ (PL(y, 1-3a, 1-2a), PL(y, 1-3a, 1-2a)), & 1-3a \leq y \leq 1-2a; \\ (-e^{-(x+a-1)^{-2}}, -2e^{-(x+a-1)^{-2}}), & 1-a \leq x; \\ (-2e^{-(y+a-1)^{-2}}, -e^{-(y+a-1)^{-2}}), & 1-a \leq y. \end{cases}$$

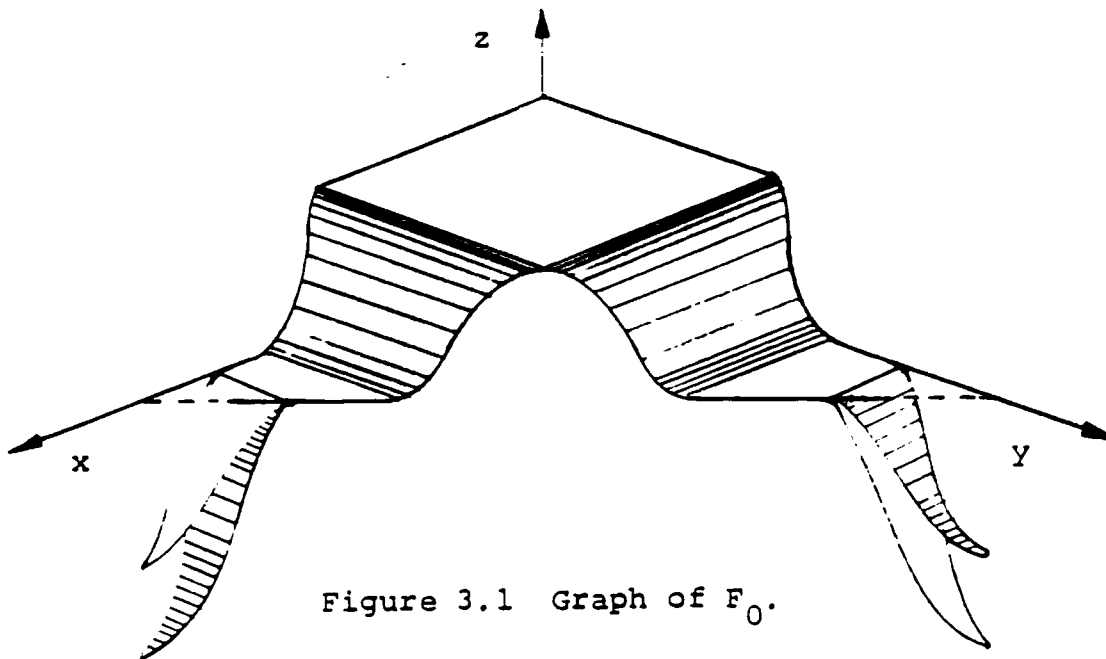

Figure 3.1 Graph of F_0 .

Note that the function F_0 satisfies (3.2i)-(3.2vi).

Namely: for (3.2i) $S_{0,2}^x - S_{0,1}^x = (1-a) - (1-2a) = a > \frac{a}{2}$.

Similarly (3.2ii) holds. For (3.2iii) note that

$\text{dist}(S_0^x, S_0^y) = \text{diam}(T) - \frac{\epsilon}{2} - \frac{\epsilon}{2} = \text{diam}(T) - \epsilon$. Observe that

(3.2iv) holds trivially since there are no B_i . For (3.2v)

note $F_0(0,0) = (1,1)$, and that $F_0(1,0)$ and $F_0(0,1)$ lie on

opposite sides of the line $y = x$. Thus T is F_0 -Sperner

triangle, since $(0,0) \in \Delta(F_0(0,0), F_0(1,0), F_0(0,1))$. Finally

we see that condition (3.2vi) holds by the definitions of

F_0 , S_0^x , and S_0^y .

Now assume that Lemma 3.2 holds for $n-1$ with func-

tion F_{n-1} . Then the information operator $N_n \in \mathcal{N}_n$ yields

functional $L_{n, F_{n-1}}$ (recall $L_{1, F_0}(\cdot) \stackrel{\text{df}}{=} L_1(\cdot)$). If

$L_1^*, \dots, L_{k_{n-1}}^*, L_{n, F_{n-1}}$ are linearly dependent on $C^\infty(T)$ then

$F_n = F_{n-1}$ will satisfy the lemma. Therefore assume

$L_1^*, \dots, L_{k_{n-1}}^*, L_{n, F_{n-1}}$ are linearly independent on $C^\infty(T)$.

Take $\gamma_n < \min(\frac{1}{2} \gamma_{n-1}, (a/2^{2n+3}))$. Then by Lemma 3.1, there

must exist a ball $B_{k_n} \subseteq T_{\gamma_n} = \{z: \text{dist}(z, T) \leq \gamma_n\}$ with

$\text{diam}(B_{k_n}) = \gamma_n$ and $k_n = k_{n-1} + 1$, such that $L_1^*, \dots, L_{k_n}^*$

$(L_{k_n}^* = L_{n, F_{n-1}})$ are linearly independent on $C(\cup_{i=1}^{k_n} B_i)$.

Two cases are possible:

Case 1) $\text{dist}(B_{k_n}, S_{n-1}^x) \geq \frac{1}{2} \gamma_n$ and $\text{dist}(B_{k_n}, S_{n-1}^y) \geq \frac{1}{2} \gamma_n$.

(i.e. B_{k_n} is at least $\frac{1}{2} \gamma_n$ away from both strips.) Then

letting $F_n = F_{n-1}$, $S_n^x = S_{n-1}^x$, $S_n^y = S_{n-1}^y$, we conclude that (3.2i)-(3.2vi) are satisfied.

Case 2) $\text{dist}(B_{k_n}, S_{n-1}^x) \leq \frac{1}{2}\gamma_n$ or $\text{dist}(B_{k_n}, S_{n-1}^y) \leq \frac{1}{2}\gamma_n$. (i.e. B_{k_n} is within $\gamma_n/2$ of one of the strips. Note that because of the separation of the strips it can not be close to both strips at one time.) Assume, without loss of generality, that $\text{dist}(B_{k_n}, S_{n-1}^x) \leq \frac{1}{2}\gamma_n$ and let $(b_{k_n}^x, b_{k_n}^y)$ be the center of the ball B_{k_n} . The two possible subcases are:

- 2a) $b_{k_n}^x \leq ((S_{n-1,1}^x + S_{n-1,2}^x)/2)$ (i.e. the ball is centered or to the left of center of the strip S_{n-1}^x).
- 2b) $b_{k_n}^x > ((S_{n-1,1}^x + S_{n-1,2}^x)/2)$ (i.e. the ball is to the right of center of the strip S_{n-1}^x).

First consider the subcase 2a) and define the function

$$h(x,y) = \begin{cases} e^{-(x-(1-2a-\gamma_n))^{-2}} (x - \frac{1}{2}(S_{n-1,1}^x + S_{n-1,2}^x) - \gamma_n)^{-2}, & 1-2a-\gamma_n \leq x \leq \frac{(S_{n-1,1}^x + S_{n-1,2}^x)}{2} + \gamma_n \\ 0 & \text{otherwise.} \end{cases}$$

And let $H_1(y,x) = (h(x,y), h(x,y))$. Now take a function

$H^1(x,y) \in C(\cup_{i=1}^{k_{n-1}} B_i)$ such that $L_i^*(H_1) = -L_i^*(H^1)$,

$i = 1, \dots, k_{n-1}$. Such a function must exist since

$L_1^*, \dots, L_{k_{n-1}}^*$ are linearly independent on $C(\cup_{i=1}^{k_{n-1}} B_i)$.

Therefore $L_{i, F_{n-1}}(H_1 + H^1) = 0$ since $L_{i, F_{n-1}}$ is a linear combination of $L_1^*, \dots, L_{k_{n-1}}^*$, for all $i = 1, \dots, n$. Let $H_1 + H^1 = (h_1, h_2)$ and choose a positive constant c so small that

$$\left(\min_{(x,y) \in (\cup_{j=1}^{k_{n-1}} B_j)} |f_{n-1}^1| \right) > c \left(\max_{(x,y) \in T} |h_1(x,y)| \right)$$

(3.3)

$$\left(\min_{(x,y) \in (\cup_{j=1}^{k_{n-1}} B_j)} |f_{n-1}^2| \right) > c \left(\max_{(x,y) \in T} |h_2(x,y)| \right)$$

and such that

(3.4) if there exists a j' such that $B_{j'}$ contains a vertex v of T , and if it is the case that $f_{n-1}^1(v) > f_{n-1}^2(v)$ (respectively $<$) then it is also the case that $(f_{n-1}^1 + ch_1)(v) > (f_{n-1}^2 + ch_2)(v)$ (respectively $<$).

Note that requirement (3.4) is needed to guarantee that T is $(F_{n-1} + c(H_1 + H^1))$ Sperner triangle. Finally let $F_n = F_{n-1} + c(H_1 + H^1)$, $S_n^Y = S_{n-1}^Y$, and

$$S_n^X = \{(x,y) \in T: S_{n,1}^X = \left(\frac{1}{2}(S_{n-1,1}^X + S_{n-1,2}^X) + \gamma_n\right) \leq x \leq S_{n,2}^X = S_{n-1,2}^X\}.$$

Now we show that the properties (3.i)-(3.2vi) are satisfied

by these choices.

i) From the induction assumption, $S_{n,1}^x > (1-2a)$ and $S_{n,2}^x < (1-a)$, moreover $S_{n,2}^x - S_{n,1}^x = S_{n-1,2}^x - \frac{1}{2}(S_{n-1,1}^x + S_{n-1,2}^x)$
 $-\gamma_n = \frac{1}{2}(S_{n-1,2}^x - S_{n-1,1}^x) - \gamma_n \geq a/(2 \cdot 2^{2(n-1)+1}) - a/(2 \cdot 2^{2n+3})$
 $= a(1/2^{2n} - 1/2^{2n+3}) \geq (a/2^{2n+1}).$

ii) is obviously true since $S_n^Y = S_{n-1}^Y$.

iii) is also obvious since $S_n^x \subseteq S_0^x$ and $S_n^Y \subseteq S_0^Y$ and

iii) holds for $n = 0$.

iv) holds for B_i , $i = 1, \dots, k_{n-1}$ from the induction assumption. For $\text{dist}(B_{k_n}, S_n^Y)$ we have $\text{dist}(B_{k_n}, S_n^Y) \geq \text{dist}(B_{k_n}, S_0^Y) \geq \gamma_0 \geq \gamma_n$. (Since we are considering the subcase 2a) we know that $\frac{1}{2}(S_{n-1,1}^Y + S_{n-1,2}^Y) \geq b_{k_n}^Y > S_{n-1,1}^Y - \gamma_n$). As for $\text{dist}(B_{k_n}, S_n^x)$ we have $b_{k_n}^x \leq \frac{1}{2}(S_{n-1,1}^x + S_{n-1,2}^x)$ and $\text{diam}(B_{k_n}) = \gamma_n$ thus we can conclude $\text{dist}(B_{k_n}, S_n^x) \geq |b_{k_n}^x + \frac{1}{2}\gamma_n - S_{n,1}^x| \geq \frac{1}{2}\gamma_n$.

v) and vi) are satisfied since the choice of the constant c was small enough to meet (3.3) and (3.4). Thus Lemma 3.2 holds for subcase 2a.

In the case 2b), we proceed as in case 2a), replacing the function $h(x,y)$ by:

$$h(x,y) = \begin{cases} -e^{-(x - \frac{1}{2}(S_{n-1,1}^x + S_{n-1,2}^x) + \gamma_n)^{-2} (x - (1-a+\gamma_n))^{-2}}, & \frac{(S_{n-1,1}^x + S_{n-1,2}^x)}{2} - \gamma_n \leq x \leq 1-a+\gamma_n \\ 0 & \text{otherwise.} \end{cases}$$

This finally completes the proof of Lemma 3.2. ■

4. Proof of the Main Theorem.

The proof is by construction of two functions of the given class F having the same information and zeros separated by $\text{diam}(T) - \epsilon$ for arbitrarily small positive ϵ .

Let us begin by defining a function $U: \mathbb{R}^2 \rightarrow \mathbb{R}^2$
 $= (u_1(x,y), u_2(x,y))$ where (see Figs. 4.1-4.2)

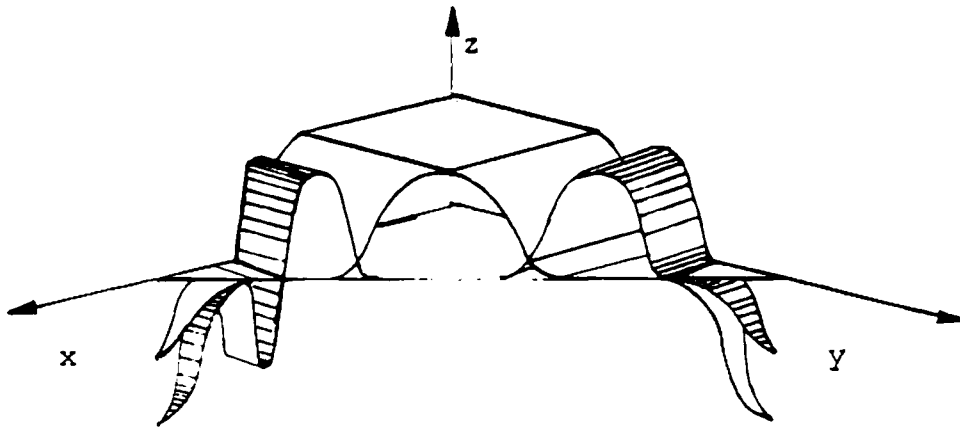

Figure 4.1 Graph of $u_1 + F_0$.

$$u_1(x,y) = \begin{cases} 1 - \text{PL}(x, S_{n-1}^x - \gamma_n, S_{n,1}^x), & (x,y) \in T: S_{n,1}^x - \gamma_n \leq x \leq S_{n,1}^x; \\ -1 + 2 \cdot \text{PL}(x, S_{n,1}^x, S_{n,2}^x), & (x,y) \in T: S_{n,1}^x \leq x \leq S_{n,2}^x; \\ -\text{PL}(x, S_{n,2}^x, S_{n,2}^x + \gamma_n), & (x,y) \in T: S_{n,2}^x \leq x \leq S_{n,2}^x + \gamma_n; \\ e^{-\frac{(y - S_{n-1}^y - \gamma_n)^2}{2}} \cdot e^{-\frac{(y - S_{n,2}^y)^2}{2}}, & (x,y) \in T: S_{n,1}^y - \gamma_n \leq y \leq S_{n,2}^y; \\ 0 & \text{otherwise.} \end{cases}$$

and $u_2 = u_2^1 \cdot u_2^2 + u_2^3$, where (see Fig. 4.2)

$$u_2^1(x, y) = \begin{cases} 1 - PL(x, S_{n,1}^x - \gamma_n, S_{n,1}^x), & (x, y) \in T: S_{n,1}^x - \gamma_n \leq x \leq S_{n,1}^x; \\ 1, & (x, y) \in T: S_{n,1}^x \leq x \leq S_{n,2}^x; \\ PL(x, S_{n,2}^x, S_{n,2}^x + \gamma_n), & (x, y) \in T: S_{n,2}^x \leq x \leq S_{n,2}^x + \gamma_n; \\ 0, & \text{otherwise.} \end{cases}$$

$$u_2^2(x, y) = \begin{cases} 1 - 2 \cdot PL(y, 0, 1 - S_{n,2}^x), & (x, y) \in T: 0 \leq y \leq (1 - S_{n,2}^x); \\ PL(y, 1 - S_{n,2}^x; 1 - S_{n,1}^x), & (x, y) \in T: (1 - S_{n,2}^x) \leq y \leq (1 - S_{n,1}^x); \\ 0, & \text{otherwise,} \end{cases}$$

and

$$u_2^3(x, y) = \begin{cases} -e^{-(y - S_{n,1}^y)^{-2} (y - S_{n,2}^y + \gamma_n)^{-2}}, & (x, y) \in T: S_{n,1}^y \leq y \leq S_{n,2}^y + \gamma_n \\ 0, & \text{otherwise.} \end{cases}$$

Now we take a function $W: \mathbb{R}^2 \rightarrow \mathbb{R}^2 = (w_1(x, y), w_2(x, y)) \in C(\cup_{j=1}^{k_n} B_j)$ such that $N(W) = -N(U)$. Again W must exist because of the linear independence of $L_1^*, \dots, L_{k_n}^*$ on $C(\cup_{j=1}^{k_n} B_j)$ (where L_i^* are the functionals from Lemma 3.2).

Next

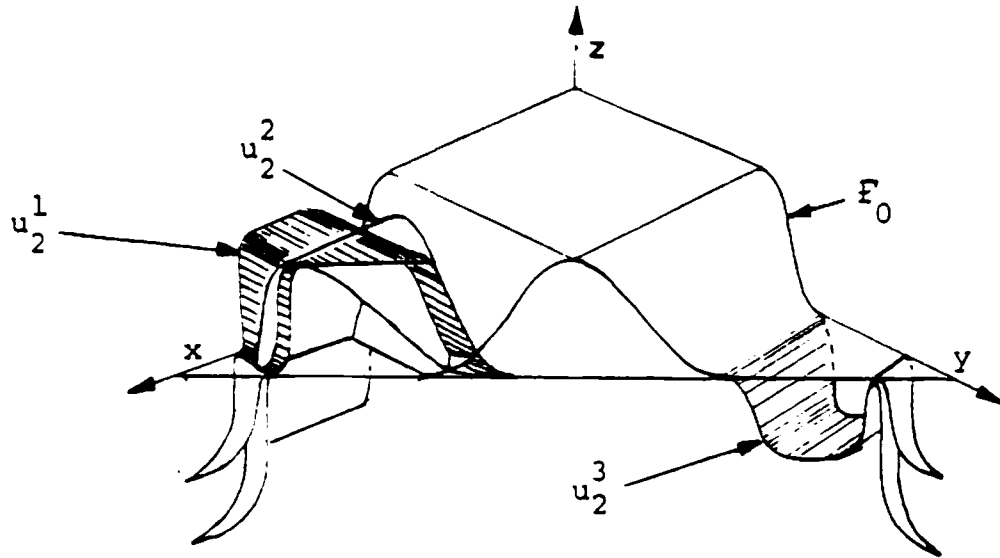

Figure 4.2 Graphs of u_2^1 , u_2^2 and u_2^3 ,

letting $F_n = (f_n^1, f_n^2)$ be the function from Lemma 3.2,

choose a constant c so small that:

$$\left(\min_{\substack{k \\ (x,y) \in (\cup_{j=1}^n B_j)}} |f_n^1| \right) > c \left(\max_{(x,y) \in T} |w_1(x,y) + u_1(x,y)| \right)$$

$$\left(\min_{\substack{k \\ (x,y) \in (\cup_{j=1}^n B_j)}} |f_n^2| \right) > c \left(\max_{(x,y) \in T} |w_2(x,y) + u_2(x,y)| \right)$$

and

if there exists a j' such that $B_{j'}$ contains a vertex v of T , and if $f_n^1(v) > f_n^2(v)$, (respectively $<$), then $(f_n^1 + c(w_1 + u_1))(v) > (f_n^2 + c(w_2 + u_2))(v)$ (respectively $<$).

Define the function $G^1 = F_n + c \cdot (U+W)$. Note that $N_n(G^1) = N_n(F_n)$, that T is a G^1 -Sperner triangle, and that G^1 has exactly one zero α which is located inside the strip S_n^x at the intersection of the line $x = \frac{1}{2}(S_{n,1}^x + S_{n,2}^x)$ and the line $y = \frac{1}{2}(1 - S_{n,2}^x)$, thus $\alpha = (\alpha_1, \alpha_2) = (\frac{1}{2}(S_{n,1}^x + S_{n,2}^x), \frac{1}{2}(1 - S_{n,2}^x))$. To see that α is a simple zero we calculate $\text{Jac}(G^1)$ at α , where $\text{Jac}(G^1)$ is the Jacobian of G^1 .

$$\begin{aligned} \text{Jac}(G^1) &= \left(\frac{\partial f_n^1}{\partial x} + c \left(\frac{\partial u^1}{\partial x} + \frac{\partial w^1}{\partial x} \right) \right) \left(\frac{\partial f_n^2}{\partial y} + c \left(\frac{\partial u^2}{\partial y} + \frac{\partial w^2}{\partial y} \right) \right) \\ &\quad - \left(\frac{\partial f_n^1}{\partial y} + c \left(\frac{\partial u^1}{\partial y} + \frac{\partial w^1}{\partial y} \right) \right) \left(\frac{\partial f_n^2}{\partial x} + c \left(\frac{\partial u^2}{\partial x} + \frac{\partial w^2}{\partial x} \right) \right). \end{aligned}$$

Observe that on S_n^x , $F_n = W = (0, 0)$ so we can reduce the equation to

$$\text{Jac}(G^1) = c^2 \left(\frac{\partial u^1}{\partial x} \cdot \frac{\partial u^2}{\partial y} - \frac{\partial u^1}{\partial y} \cdot \frac{\partial u^2}{\partial x} \right).$$

Using the fact that on S_n^x , $(\partial u^1 / \partial y) = 0$ and $(\partial u^2 / \partial x) = 0$ we have $\text{Jac}(G^1)|_{\alpha} = c^2 (\partial u^1 / \partial x)|_{\alpha} \cdot (\partial u^2 / \partial y)|_{\alpha}$.

Then recalling the definition of U note that in a sufficiently small neighborhood of α ,

$U = ((-1 + 2 \cdot \text{PL}(x, S_{n,1}^x, S_{n,2}^x)), (1 - 2 \cdot \text{PL}(y, 0, 1 - S_{n,2}^x)))$. (Note that this implies that α occurs where $\text{PL}(z, a, b) = \frac{1}{2}$, but since the integrand is symmetric with respect to its argument the value of the integral at the midpoint is

obviously $\frac{1}{2}$ the total integral). Therefore

$$\begin{aligned} \text{Jac}(G^1)|_{\alpha} &= -4 \cdot c^2 \left(\frac{\partial}{\partial x} (\text{PL}(x, S_{n,1}^x, S_{n,2}^x)) \Big|_{\alpha} \right) \\ &\quad \left(\frac{\partial}{\partial y} (\text{PL}(y, 0, 1 - S_{n,2}^x)) \Big|_{\alpha} \right). \end{aligned}$$

Now noting that $\partial/\partial z (\text{PL}(z, a_1, a_2))$

$$= e^{-(z-a_1)^{-2} (z-a_2)^{-2}} \int_{a_1}^{a_2} e^{-((t-a_1)^{-2} (t-a_2)^{-2})} dt, \text{ and recalling}$$

$\alpha = (\frac{1}{2}(S_{n,1}^x + S_{n,2}^x), \frac{1}{2}(1 - S_{n,2}^x))$ we have

$$\text{Jac}(G^1)|_{\alpha} = c^* \cdot e^{\left(\frac{1}{2}(S_{n,1}^x + S_{n,2}^x)\right)^2} \cdot e^{\left(\frac{1}{2}(1 - S_{n,2}^x)\right)^2},$$

where c^* is a non-zero constant. Therefore we can conclude that $\text{Jac}(G^1)|_{\alpha} \neq 0$ and that G^1 is a member of our class F .

Next we similarly construct a function G^2 in F with one simple zero in S_n^y , such that $N_n(G^2) = N_n(F_n)$. Therefore $N_n(G^1) = N_n(G^2)$. Thus for arbitrarily small positive ϵ , we have constructed two functions in our class with the same information whose zeros are separated by at least $\text{diam}(T) - \epsilon$. (Recall that zeros are in S_n^y, S_n^x and by (3.2iii) these are separated by at least $\text{diam}(T) - \epsilon$). The theorem follows by taking the limit as $\epsilon \rightarrow 0$. ■

Acknowledgements.

We are indebted to J.F. Traub and H. Woźniakowski
for their valuable comments on the manuscript.

References

- [1] Allgower, E.L., Georg, K., *Simplicial and Continuation Methods for Approximating Fixed Points and Solutions to Systems of Equations*, SIAM Rev. 22 (1980), pp. 28-85.
- [2] Eaves, B.C., *A Short Course in Solving Equations with PL Homotopies*. SIAM-AMS Proc., 9, (1976), pp. 73-143.
- [3] Eaves, B.C., Gould, F.J., Peitgen, H.O., Todd, M.J., ed., *Homotopy Methods and Global Convergence*, Plenum Press, New York and London, 1983.
- [4] Ortega, J.M., Rheinboldt, W.C., *Iterative Solution of Nonlinear Equations in Several Variables*, Academic Press, New York, 1970.
- [5] Sikorski, K., *Bisection is Optimal*, Numer. Math. 40 (1982), pp. 111-117.
- [6] Sikorski, K., Woźniakowski, H., *For Which Error Criteria Can we Solve Nonlinear Equations*, Dept. Computer Science Report, Columbia University, 1983.
- [7] Todd, M.J., *The Computation of Fixed Points and Applications*, Springer Lecture Notes in Economics and Mathematical Systems, 124, Springer Verlag, Heidelberg-New York, 1976.
- [8] Traub, J.F., Woźniakowski, H., *A General Theory of Optimal Algorithms*, Academic Press, New York, 1980.
- [9] Yoshida, K., *Functional Analysis 6th Ed.* Berlin, Springer-Verlag, 1980.